

CYCLONE 150

Steerable Wheel Drive



Floor
Care



Mobile Robots
& AGVs



Material
Handling

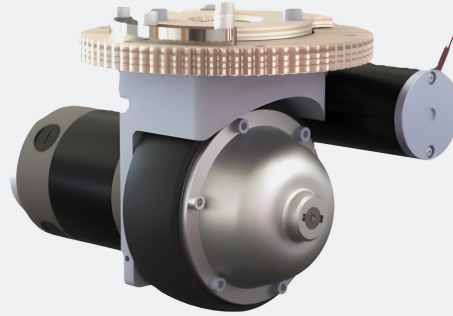

FEATURES

Sealed drive system: Rugged, compact, integrated steer motor

Optional components: Electromagnetic power-off brake, encoders, connectors

Voltage: 24V to 48V VDC

Wheel: Integral 6 in [152.4 mm] diameter

Gear set: Two-stage planetary

Brake options available: 6 Nm

Motor options available: Permanent magnet DC 4-pole, brushless DC

Reduction ratio: 9:1 to 23.2:1

PERFORMANCE EXAMPLE

Sample Application Data			
Maximum Wheel Load	900 lbs [408 kg]	Motor Type	PMDC
Rated Towing Weight	1720 lbs [780 kg]	Wheel Material	Polyurethane
Maximum Speed	190 ft/min [.97 m/s]	Rated Current Draw (Continuous)	13A

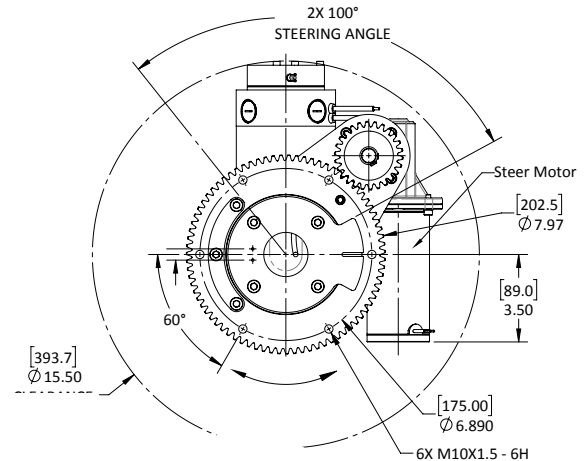
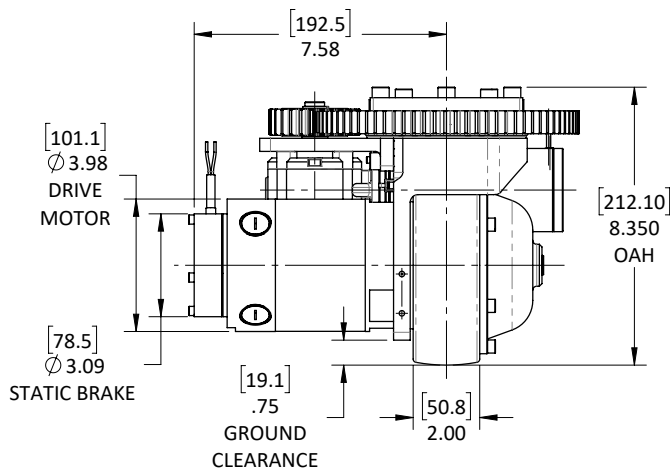



RESULTS.
DRIVEN.

Lasting solutions to drive your machines. More than industrial designers and engineers, we're a team of passionate problem solvers. ASI Drives: Gear drive systems for battery powered machines up to one ton.

OUR CUSTOMERS HAVE BEEN WITH US FOR OVER **15 YEARS ON AVERAGE BECAUSE OF OUR:**

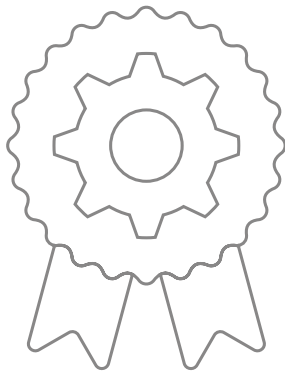

DEEP EXPERTISE:

Creating over 740 tailored engineered solutions

Offering cost sensitive designs with manufacturing efficiencies

A history of innovation recognized with 7 awarded patents

In-house gear manufacturing offers supply chain predictability



OUR 40-YEAR COMMITMENT:

Excellent customer service

"Best in class" partnership with OEM industry leaders

Our entrepreneurial size ensures personal executive level accountability and responsiveness



DEEP INDUSTRY KNOWLEDGE & FOCUS:

Insights and solutions to your specific challenges & opportunities

We know your competitive landscape

EXPERIENCE THE DIFFERENCE OUR DEDICATION TO INNOVATION, QUALITY AND SERVICE MAKES.

Contact us at sales@asidrives.com to explore how we can quickly solve your most pressing challenges.

