

THUNDER 1500HD

Heavy Duty Two-Stage IPM Motor Wheel Drive



Mobile Robots
& AGVs



Material
Handling



Outdoor Power
Equipment

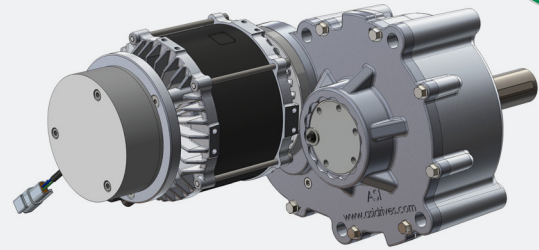

FEATURES

Sealed drive system: Rugged, usable outdoors

Optional components: Electromagnetic power-off brake

Motor: Interior permanent magnet, 5.5 in [140 mm] diameter, brushless
48 volt with internal encoder and thermal sensor, connectors,
IP69K conformity

Axle material: Hardened carbon steel

Gear set: Two-stage helical

Reduction ratio: 20.9:1 or 31:1

PERFORMANCE EXAMPLES

High Torque				
Duty Type	S2-2min	S2-10min	S2-30min	S2-60min
Torque, Nm	883	589	368	282
Power, kW	2.98	5.97	4.97	3.34
Speed, rpm	32	97	129	113
Efficiency, %	58	81	86	88
Phase Current, Amps	200	140	100	65
Stator Frequency, Hz	83	250	333	292

High Speed				
Duty Type	S2-2min	S2-10min	S2-30min	S2-60min
Torque, Nm	596	397	248	191
Power, kW	2.98	5.97	4.97	3.34
Speed, rpm	48	143	191	167
Efficiency, %	58	81	86	88
Phase Current, Amps	200	140	100	65
Stator Frequency, Hz	83	250	333	292

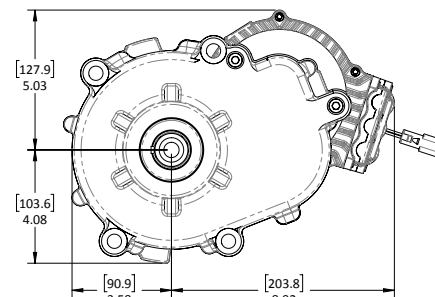
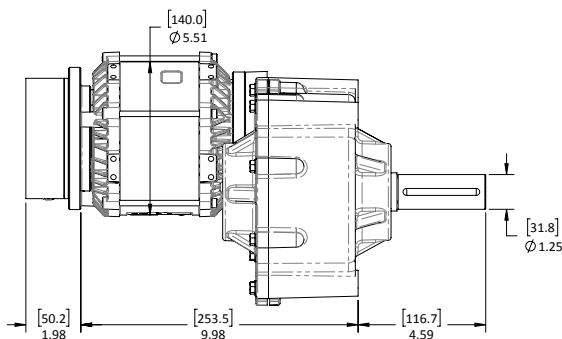
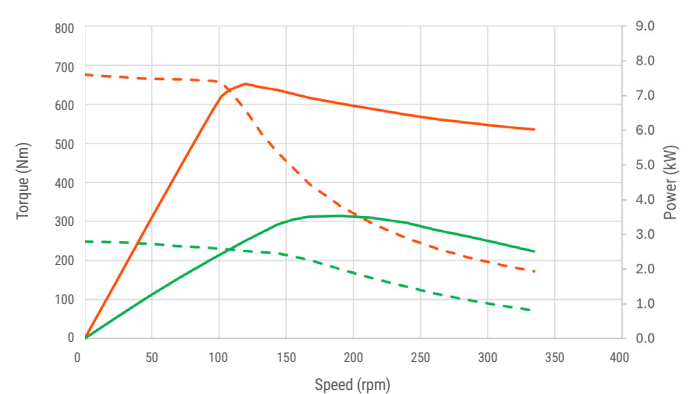
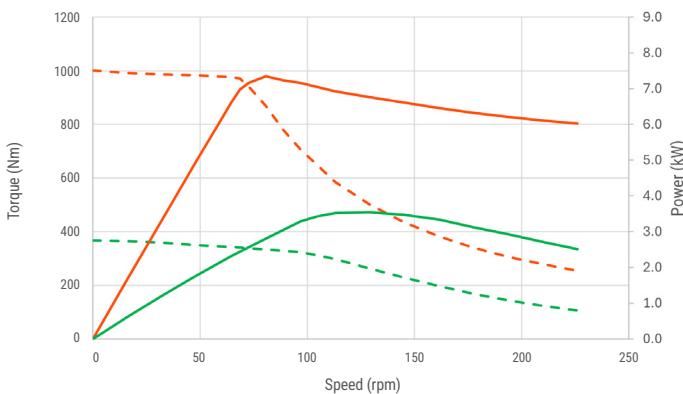



RESULTS.
DRIVEN.

Lasting solutions to drive your machines. More than industrial designers and engineers, we're a team of passionate problem solvers. ASI Drives: Gear drive systems for battery powered machines up to one ton.

OUR CUSTOMERS HAVE BEEN WITH US FOR OVER **15 YEARS ON AVERAGE BECAUSE OF OUR:**

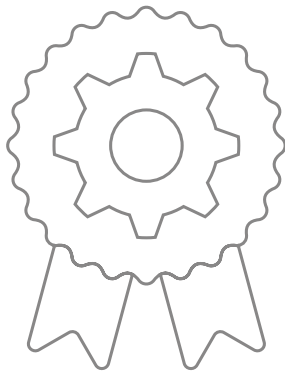

DEEP EXPERTISE:

Creating over 740 tailored engineered solutions

Offering cost sensitive designs with manufacturing efficiencies

A history of innovation recognized with 7 awarded patents

In-house gear manufacturing offers supply chain predictability



OUR 40-YEAR COMMITMENT:

Excellent customer service

"Best in class" partnership with OEM industry leaders

Our entrepreneurial size ensures personal executive level accountability and responsiveness



DEEP INDUSTRY KNOWLEDGE & FOCUS:

Insights and solutions to your specific challenges & opportunities

We know your competitive landscape

EXPERIENCE THE DIFFERENCE OUR DEDICATION TO INNOVATION, QUALITY AND SERVICE MAKES.

Contact us at sales@asidrives.com to explore how we can quickly solve your most pressing challenges.

