

CYCLONE 700

Steerable Wheel Drive



Floor Care



Mobile Robots & AGVs

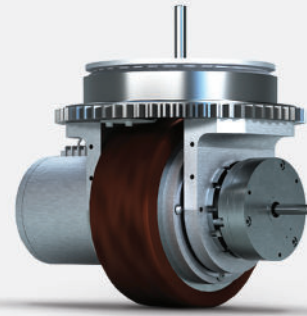

FEATURES

Sealed drive system: Rugged; compact

Optional components: Electromagnetic power-off brake, encoder, safety encoder, connectors, brake cover, IP67 conformity

Voltage: 48V DC

Wheel: Integral 200 mm diameter

Gearing: Helical compound planetary

Brake options available: Up to 12 Nm

PERFORMANCE EXAMPLE

Sample Application Data			
Maximum Wheel Load	1,500 lbs	Motor Type	BLDC with Hall Effect Board
Maximum Grade	7%	Gear Ratio Between Encoder Shaft and Output Shaft	20:1
Minimum Speed Loaded on Level Ground	393 ft/min	Acceleration on Level Ground	0.5 m/s ²
Minimum Speed Loaded on Grade	300 ft/min	Power Consumption Fully Loaded on 7% Grade at 300 ft/min	1.47 kW

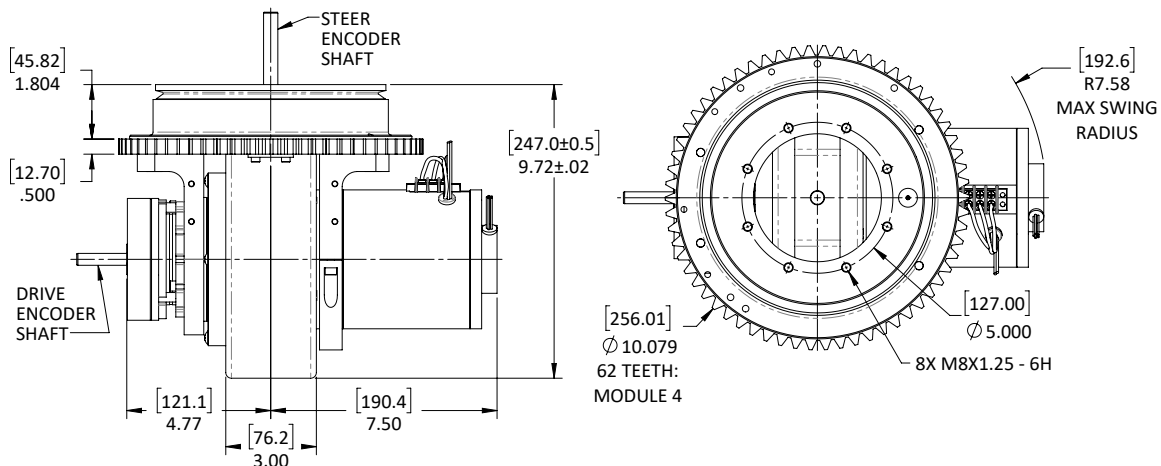



Lasting solutions to drive your machines. More than industrial designers and engineers, we're a team of passionate problem solvers. ASI Drives: Gear drive systems for battery powered machines up to one ton.

OUR CLIENTS HAVE BEEN WITH US FOR **OVER 14 YEARS BECAUSE OF OUR:**

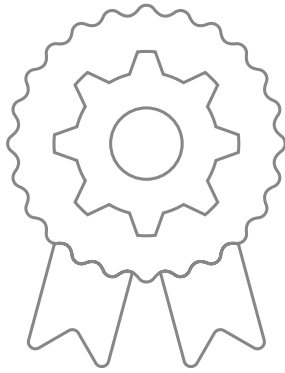

DEEP EXPERTISE:

Creating over 740 tailored engineered solutions

Offering cost sensitive designs with manufacturing efficiencies

A history of innovation recognized with 7 awarded patents

In-house gear manufacturing offers supply chain predictability



OUR 38-YEAR COMMITMENT:

Excellent customer service

"Best in class" partnership with OEM industry leaders

Our entrepreneurial size ensures personal executive level accountability and responsiveness



DEEP INDUSTRY KNOWLEDGE & FOCUS:

Insights and solutions to your specific challenges & opportunities

We know your competitive landscape

EXPERIENCE THE DIFFERENCE OUR DEDICATION TO INNOVATION, QUALITY AND SERVICE MAKES.

Contact us at sales@asidrives.com to explore how we can quickly solve your most pressing challenges.

