

# CYCLONE 700

Steerable Wheel Drive



Floor  
Care



Mobile Robots  
& AGVs

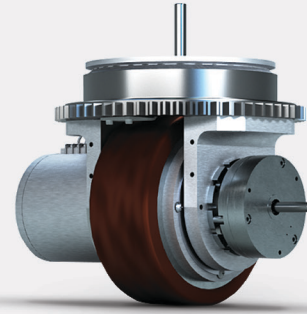

## FEATURES

**Sealed drive system:** Rugged; compact

**Optional components:** Electromagnetic power-off brake, internal encoder, safety encoder, connectors, brake cover, IP67 conformity

**Voltage:** 48V DC

**Wheel:** Integral 200 mm diameter

**Gearing:** Helical compound planetary

**Brake options available:** Up to 12 Nm

## PERFORMANCE EXAMPLES

Performance Example			
Maximum Wheel Load	1,500 lbs	Power Consumption Fully Loaded on 7% Grade at 300 ft/min	1.47 kW
Maximum Grade	7%	Estimated Gearbox Efficiency	>90%
Rolling Resistance	0.025	Acceleration on Level Floor	0.5 m/s <sup>2</sup>
Minimum Speed Loaded on Level Ground	393 ft/min	Drive Backlash	<1 Deg
Minimum Speed Loaded on Grade	300 ft/min	Brake Holding Torque	12NM
Motor Type	Brushless DC with Hall Effect Board	Gear Ratio Between Encoder Shaft and Output Shaft	20:1
Power Consumption Fully Loaded at 393 ft/min	0.38 kW	Thermal Switch Cutoff	105°C

