

PLUTO

Right Angle Worm Drive for Stair Lifts

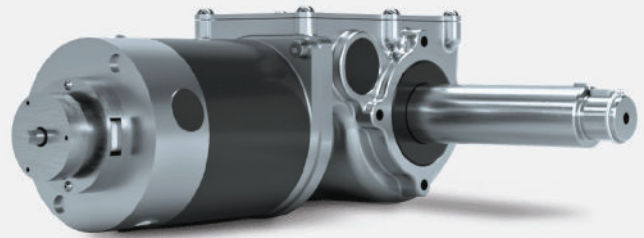

Stair Lift



FEATURES

Motors: Permanent magnet DC 4-pole, 3.98 in (101 mm) diameter, brushless DC option

Voltage: 24V DC

Optional components: Electromagnetic power-off brake, internal encoder

Encoder options available: Digital position and motion information

Output shaft: Hardened carbon steel

Reduction ratio: 72:1

Weight capacity: 350 lbs.

PERFORMANCE EXAMPLE

24V Option			
	No Load	Typical	High
Torque, Nm	0	65	87
RPM	35	30	28
Current, Amps	1.5	14.0	18.0
Power Out, Watts	0	201	253
Power In, Watts	36	336	432
Efficiency	0%	60%	58%

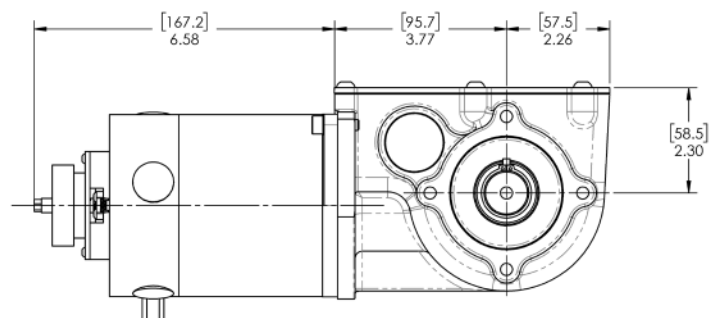
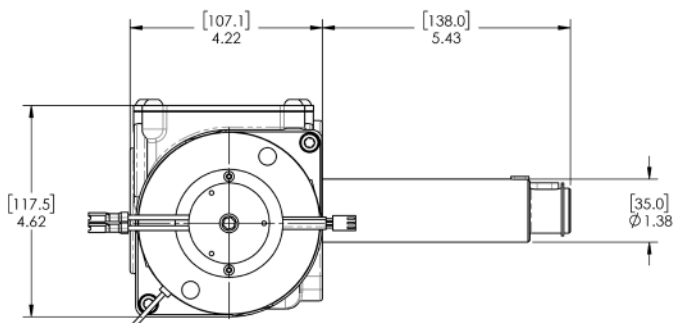



Lasting solutions to drive your machines. More than industrial designers and engineers, we're a team of passionate problem solvers. ASI Drives: Gear drive systems for battery powered machines up to one ton.

OUR CLIENTS HAVE BEEN WITH US FOR **OVER 14 YEARS BECAUSE OF OUR:**

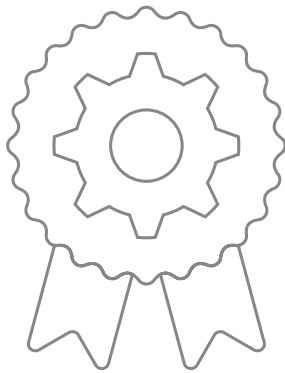

DEEP EXPERTISE:

Creating over 740 tailored engineered solutions

Offering cost sensitive designs with manufacturing efficiencies

A history of innovation recognized with 7 awarded patents

In-house gear manufacturing offers supply chain predictability



OUR 38-YEAR COMMITMENT:

Excellent customer service

"Best in class" partnership with OEM industry leaders

Our entrepreneurial size ensures personal executive level accountability and responsiveness

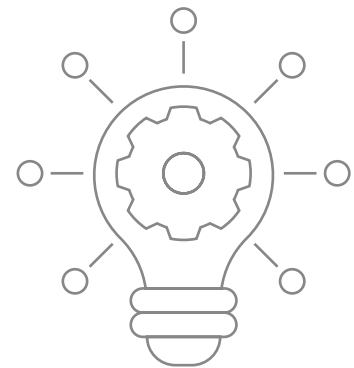

DEEP INDUSTRY KNOWLEDGE & FOCUS:

Insights and solutions to your specific challenges & opportunities

We know your competitive landscape

EXPERIENCE THE DIFFERENCE OUR DEDICATION TO INNOVATION, QUALITY AND SERVICE MAKES.

Contact us at sales@asidrives.com to explore how we can quickly solve your most pressing challenges.

